



洲光源
CHAULIGHT

产品规格书 SPECIFICATION

客户名称: _____

Customer Name

产品类型: _____ 贴片式可见光

Product Name

产品型号: _____ ZGH-1608C-06H-Z5

Part No.

<input type="checkbox"/> 技术参考 Technical Reference		<input type="checkbox"/> 样品 Sample		<input type="checkbox"/> 量产供货 Mass Product	
客户审核 (加盖公章) Client approval (Stamp)			洲光源审核 Chaulight approval		
核准Approval	确认Checked	核准Approval	确认Checked	制作Edited	
		郝三强	李兆海	黄愉舒	
<input type="checkbox"/> 接收 Qualified			<input type="checkbox"/> 不接收 Disqualified		日期 Date: 2020-12-31

联系电话(Tel): 0760-88504720

传真(Fax): 0760-88504721

地址(Add): 广东省中山市东升镇联胜南路 3 号洲光源科技园

No.3,Lian Sheng South Road ,Dong Sheng Town,Zhongsan City,Guang Dong Province.

本规格书仅用于双方交流用需经双方签订后方可生效, 自签订后有效期为两年, 期满后需以书面形式续签。最终解释权为洲光源所有。

This product specification is only used for technical communication.Only after the signature or seal, the specifications have the force of law.since the signing of the validity period of two years, after the expiration of the written renewal. The final interpretation right is owned by the CHAULIGHT.

广东洲光源红外半导体有限公司
Guangdong Chaulight Infrared Semiconductor Co.,Ltd.

此材料比直插式组件小，从而板的尺寸更小，堆积密度更高，占用空间减少，最终获得更小的设备。

The Taping is much smaller than lead frame type components, thus enable smaller board size, higher packing density, reduced storage space and finally smaller equipment to be obtained.

特性 Feature

--发光角度大

Extremely wide viewing angle

--适用于所有的SMT 组装和焊接工艺、适用于载带及卷轴

Suitable for all SMT assembly and solder process、Available on tape and reel

--无铅材料、Rohs 认证

Pb.Free、RoHS compliant version

应用 Application

--光学指示、室内显示、LCD 背光、转换器，开关和标志，显示器等、一般应用

Optical indicator、Indoor display、Backlight for LCD, switch and Symbol, display、General use

最大额定值 Absolute Maximum Ratings

测试项目 Parameter (Ta=25℃)	符合 Symbol	范围 Ratings	单位 Unit
功率 Power Dissipation *1	Pd	60	mW
反向电压 Reverse Voltage	V _R	5	V
持续正向电流 Forward Current	I _F	25	mA
脉冲正向电流 Peak Forward Current *2	I _{FP}	60	mA
工作温度 Operating Temperature	T _{opr}	-25~+85	℃
储存温度 Storage Temperature	T _{stg}	-40~+85	℃
焊接温度 Lead Soldering Temperature *3	T _{sol}	260	℃
静电防护 Electrostatic Discharge (HBM)	ESD	2000	V

*1、在 25 摄氏度的环境中测试 below 25 Free Air Temperature

*2、回流焊：260 度 5 秒钟内、手焊：350 度 3 秒钟内

Reflow Soldering : 260℃ for 5 sec、Hand Soldering : 350℃ for 3 sec

产品尺寸 Package Dimension

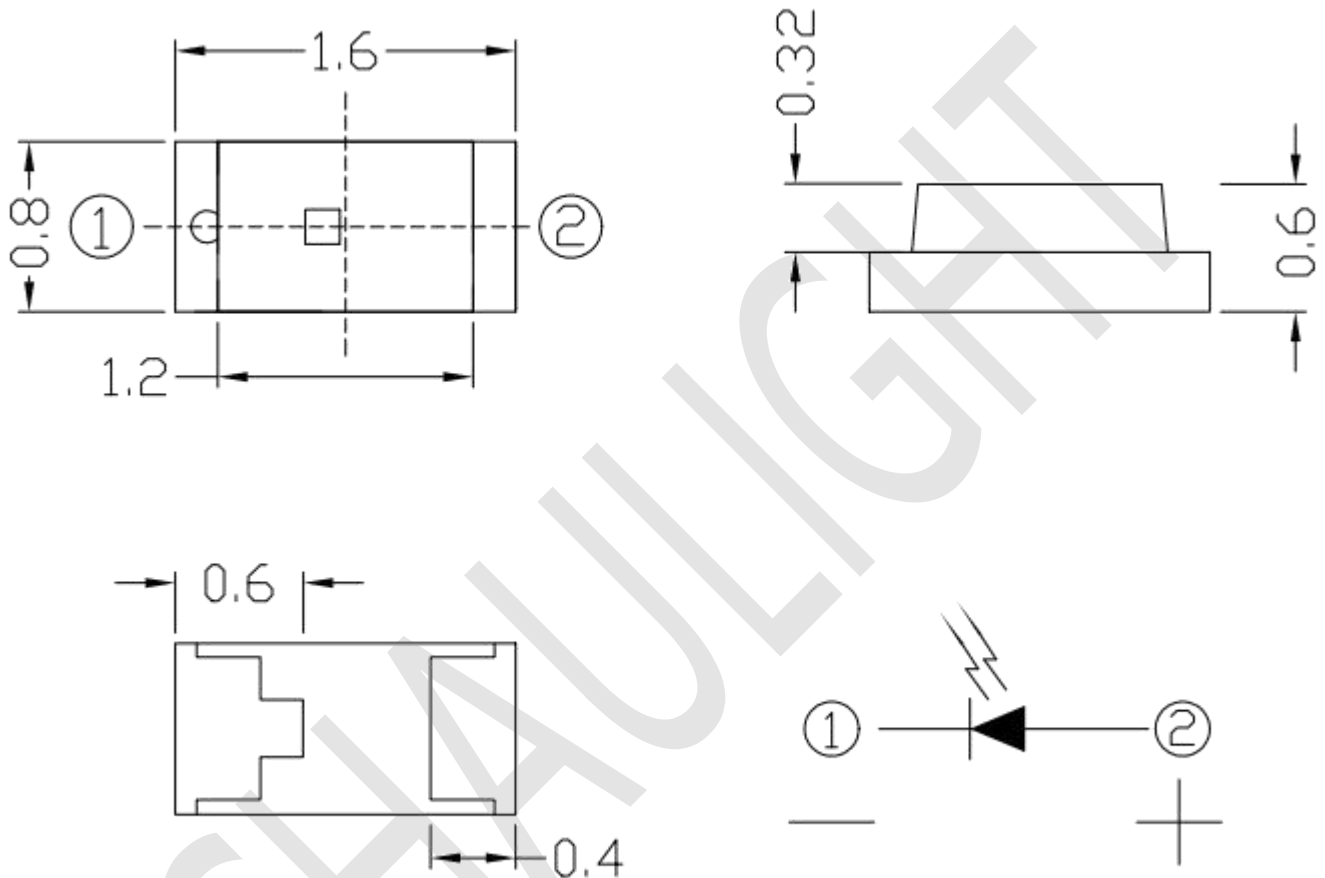

备注Notes:

--所有尺寸为毫米标识

All dimensions are in millimeters

--未标识尺寸正负公差为 0.3mm

Tolerances unless dimensions $\pm 0.3\text{mm}$

光电特性 Electro-Optical Characteristics

电性参数 (温度=25℃) Parameter (Ta=25℃)	符号 Symbol	条件 Condition	最小值 Min.	典型值 Typ.	最大值 Max.	单位 Units
光强Luminous intensity	Iv	I _F =20mA	112.0	--	285.0	mcd
峰值波长Peak Wavelength	λ _p	I _F =20mA	--	518.0	--	nm
主波长Peak Wavelength	λ _d	I _F =20mA	520.0	--	535.0	nm
光谱带宽Spectral Bandwidth	Δλ	I _F =20mA	--	35	--	nm
正向电压Forward Voltage	V _F	I _F =20mA	--	3.5	4.0	V
反向电流Reverse Current	I _R	V _R =5V	--	--	50	μA
发光角度View Angle	2θ1/2	I _F =20mA	--	120	--	deg

亮度档位 Luminous Intensity Rank Combination

档位Rank	符号 Symbol	条件Condition	最小值Min.	最大值 Max.	单位Unit
R1	Iv	I _F =20mA	112.0	140.0	mcd
R2			140.0	180.0	
S1			180.0	225.0	
S2			225.0	285.0	

波长档位 Dominant wavelength Rank Combination

档位Rank	符号 Symbol	条件Condition	最小值Min.	最大值 Max.	单位Unit
X	λ _d	I _F =20mA	520.0	525.0	nm
Y			525.0	530.0	
Z			530.0	535.0	

备注Notes:

- 正向电压的测量公差是±0.1V Measurement Uncertainty of Forward Voltage: ±0.1V
- 发光强度的测量公差是±10% Measurement Uncertainty of Luminous Intensity: ±10%
- 峰值波长的测量公差是±1.0nm Measurement Uncertainty of Dominant Wavelength ±1.0nm

典型光电特性曲线图 Typical Electro-Optical Characteristics Curves

正向电流与环境温度的关系

Forward Current vs. Ambient Temperature

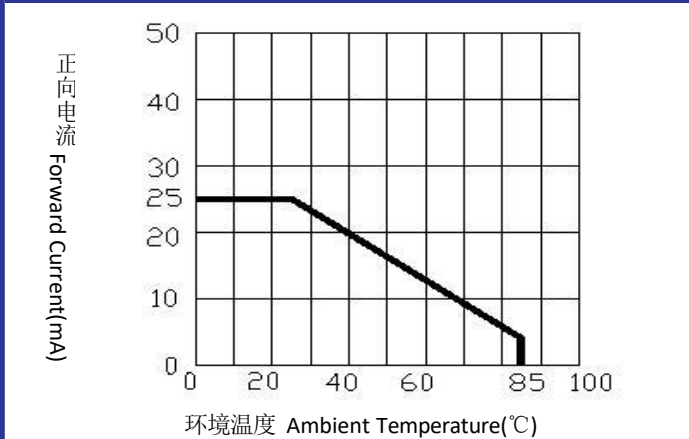

正向电流与正向电压的关系

Forward Current vs. Forward Voltage

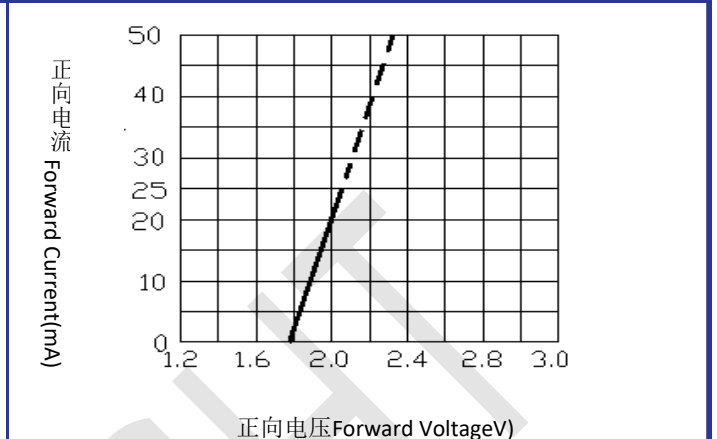

光强度特性与正向电流的关系

Radiant Intensity vs. Forward Current

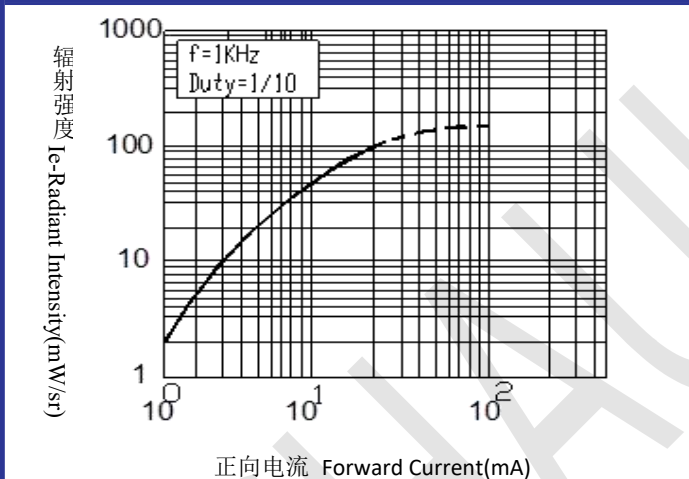

波长曲线图

Spectral Distribution

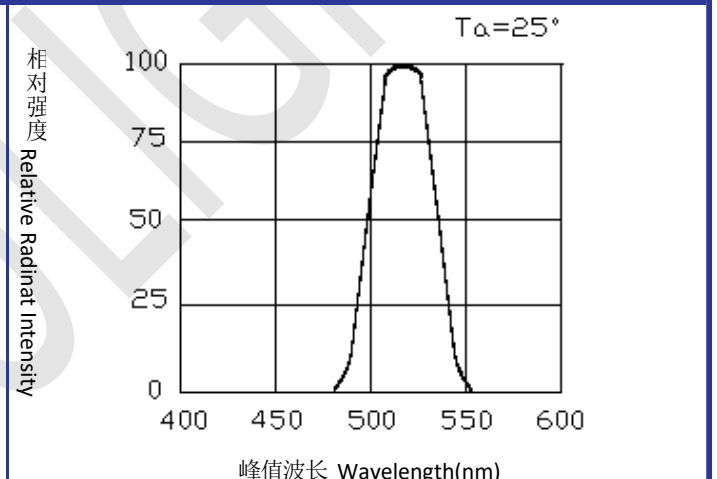

光强度与环境温度的关系

Relative Intensity vs. Ambient Temperature

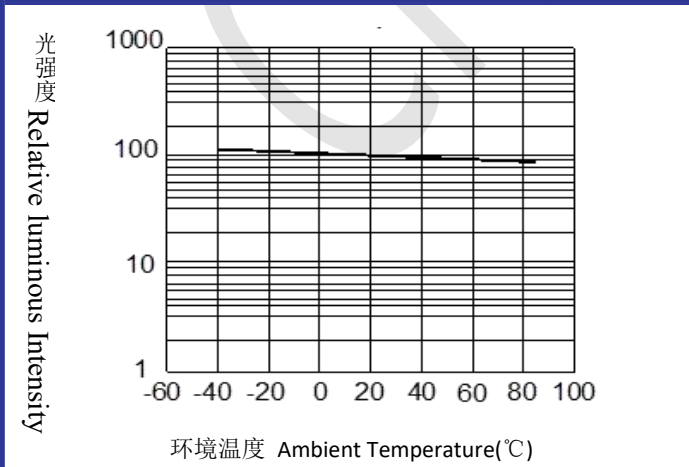

光强度与角位移的关系

Relative Radiant Intensity vs. Angular Displacement

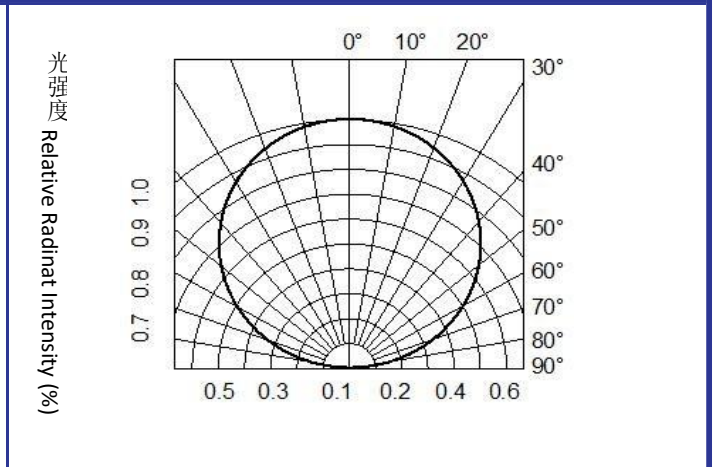

包装规格 Packing Specification

标签格式 Label

CAT: Luminous intensity rank 亮度等级

HUE: Dominate Wavelength 波长等级

REF: Forward voltage rank 电压等级

载带规格 Tape Specifications (单位: mm)(Units : mm) (包装每卷 5000PCS) 5000pcs/reel

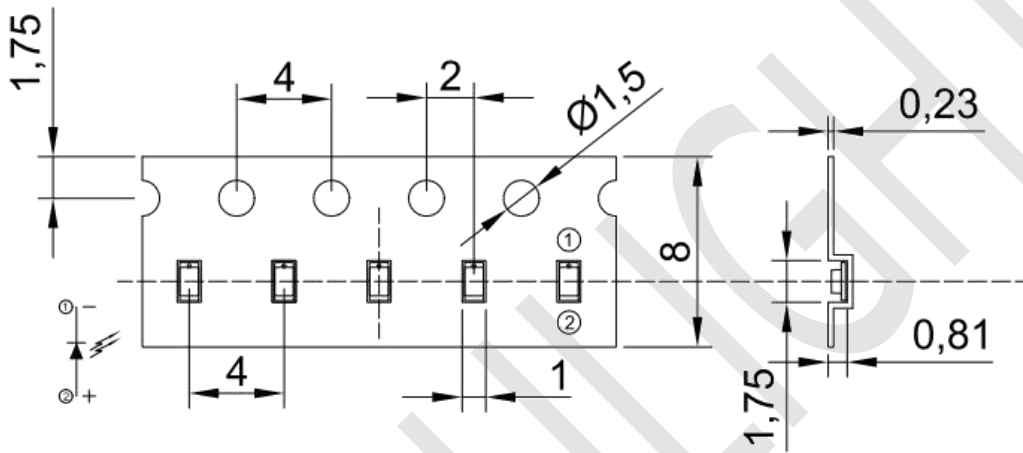

卷轴尺寸
Reel Dimensions

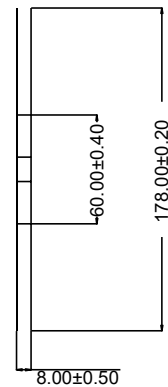
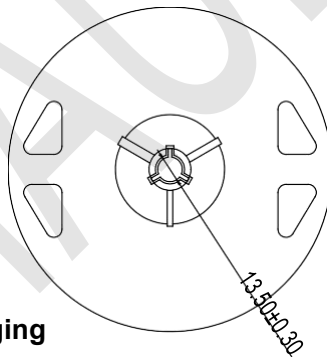

防潮带包装 Moisture Resistant Packaging

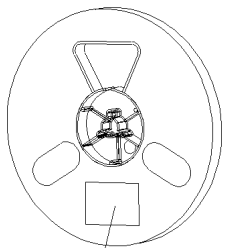

Label

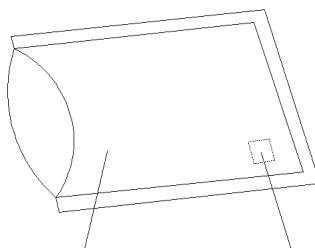
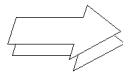

Aluminum moisture-proof bag

Desiccant

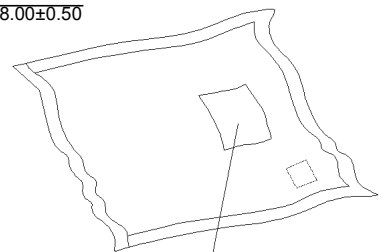
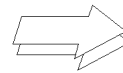

Label

注: 标注公差为±0.1mm, 单位: mm Note: The tolerances unless mentioned is ±0.1mm, Unit: mm

► 注意事项 Note

--储存 Storage

1、该产品出厂后贮存的条件应为 $0\sim+30^{\circ}\text{C}$ 、相对湿度不大于 70%，贮存期限为 3 个月。若贮存超过 3 个月，则应放在带有氮气和干燥剂的密闭容器内，贮存时间可达一年。The storage conditions of the product after leaving the factory shall be $0\sim30^{\circ}\text{C}$, the relative humidity shall not be greater than 70%, and the storage period shall be 3 months. If stored for more than 3 months, it should be placed in a sealed container with nitrogen and desiccant for up to one year.

2、拆袋使用，应尽可能短时间内用完，若用不完，应满足贮存条件应为 $0\sim+30^{\circ}\text{C}$ 。相对湿度不大于 60%，并在 2 天内安装完。产品支架是铁合金表面上镀银，银表面会受到腐蚀性气体等环境的影响，应避免使产品处于易腐蚀或失去光泽的环境中，这会导致产品焊接困难。Use of bag removal, should be used as short as possible, if not used, should meet the storage conditions should be $0\sim30^{\circ}\text{C}$. The relative humidity is not more than 60% and is installed in 2 days. The product support is silver plated on the surface of ferroalloy, the silver surface will be affected by corrosive gas and other environment, should avoid making the product in the environment of easy corrosion or loss of luster, which will lead to difficult welding of the product.

烘烤处理： $60\pm 5^{\circ}\text{C}$ ，24 小时。Bake treatment: $60\pm 5^{\circ}\text{C}$, 24 hours.

--焊接 Soldering

1、胶体不可侵入锡槽内。Epoxy non-invasive tin tank.

2、加热过程中不能对引脚施加压力。Pin pressure can not be applied during heating.

3、回流焊不应做一次以上。Reflux welding shall not be done more than once.

注：建议客户尽量使用较低的温度和较短的时间进行焊接；在符合以上推荐回流曲线条件下的死灯上限为 500PPM。Note: Customers are advised to use lower temperature and shorter time for welding as far as possible; the upper limit of dead lamp under the condition of PPM. above recommended reflux curve is 500.

4、建议客户在经波峰焊后加装风扇，以利散热，需等 LED 冷却后（最好为室温后），再进行下一工序加工。Customers are advised to install fan after wave peak welding to facilitate heat dissipation, need to wait for LED cooling (preferably after room temperature) before the next process processing.

推荐回流焊曲线 Recommended Reflow Welding Curves:

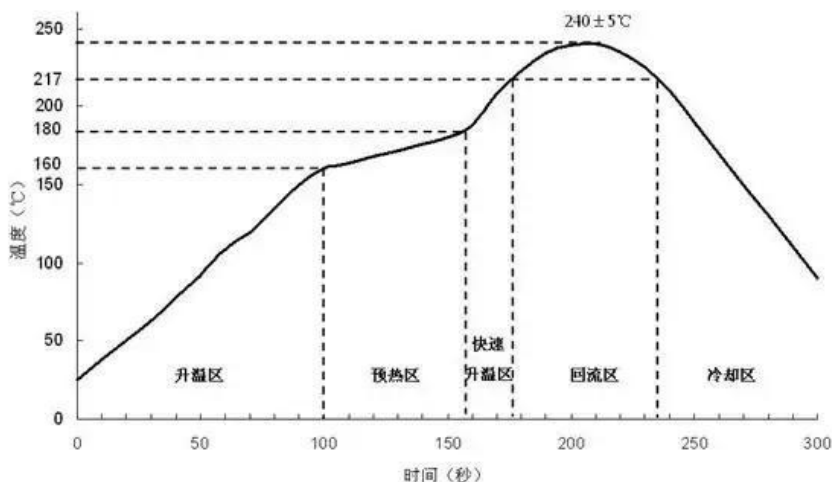

--清洗 Cleaning

- 1、在任何情况下，清洗时间应在常温 1 分钟之内进行。In any case, the cleaning time should be within 1 minute of normal temperature.
- 2、清洗产品时推荐使用酒精作为清洗剂，如使用其他清洗剂，需先确认清洗剂是否会腐蚀环氧体。氟利昂不能作为清洗剂。It is recommended to use alcohol as cleaning agent when cleaning products. If other cleaning agents are used, it is necessary to confirm whether the cleaning agent will corrode the epoxy body first. Freon can't be a cleaning agent.
- 3、不可用水清洗，以免腐蚀引线，建议使用酒精。Do not wash with water to avoid corrosion of leads, alcohol is recommended
- 4、用超声波清洗产品时，超声波功率和时间分别小于 300W 和 30 秒；PCB 和产品不能接触振荡器，不能使 PCB 上的产品产生共振。When cleaning the product with ultrasonic, the ultrasonic power and time are less than 300 W and 30 seconds, respectively; PCB and products can not contact the oscillator, can not make the product on the PCB resonance.
- 5、本型号为静电敏感器件，所以静电和电泳会损坏产品，要求使用时佩戴防静电手环，所有的装置、设备、机器、桌子、地面都必须防静电接地。This model is electrostatic sensitive device, so electrostatic and electrophoretic will damage the product, it is required to wear anti-static bracelet when all devices, equipment, machines, tables, ground must be anti-static grounding.

--其他 Other

- 1、以上规格可更改，恕不另行通知。洲光源将为上述规格的材料变更保留权力 Above specification may be changed without notice. CHAU LIGHT will reserve authority on material change for above specification.
- 2、当使用此产品时，请观察这些规格表中概述的绝对最大额定值和使用说明。洲光源不承担任何损坏结果的责任从不符合绝对最大额定值的产品的使用和这些规格表中包含的说明 When using this product, please observe the absolute maximum ratings and the instruction for using outlined in these specification sheets. CHAU LIGHT assumes no responsibility for any damage resulting from use of the product which does not comply with the absolute maximum ratings and the instructions included in these specification sheets.
- 3、此规格书版权属广东洲光源红外半导体有限公司。未经允许不得转载或复印。These specification sheets include materials protected under copyright of CHAU LIGHT corporation. Please don't reproduce or cause anyone to reproduce them without CHAU LIGHT's consent.

更改记录表 Engineering Change Notice-Record

版本 Edition	更改日期 Date	主要更改内容 Main Content	拟制 Prepared	确认 Checked
1.1	2020-12-31	新版本发布New Edition	黄愉舒	郝三强